

A Novel Multilevel Inverter based Micro Grid and ITS Co-Ordination Control

Guntuku Ravikiran, Mohammed Jaffar, Kadiyam Sasidhar

Abstract: This thesis first proposes a hybrid ac/dc micro-grid and its coordination control for reducing the processes of multiple conversions in an individual ac or dc grid. Renewable energy based distributed generators (DGs) play a dominant role in electricity production, with the increase in the global warming. Distributed generation based on wind, solar energy, biomass, mini-hydro along with use of fuel cells and micro-turbines will give significant momentum in near future. Advantages like environmental friendliness, expandability and flexibility have made distributed generation, powered by various renewable and nonconventional micro-sources. The micro-grid concept introduces the reduction of multiple reverse conversions in an individual AC or DC grid and also facilitates connections to variable renewable AC and DC sources and loads to power systems. The interconnection of DGs to the utility/grid through power electronic converters has risen concerned about safe operation and protection of equipment's. To the customer the micro-grid can be designed to meet their special requirements. In the present work the performance of hybrid AC/DC micro-grid system is analyzed in the grid tied mode. Here photovoltaic system, wind turbine generator and battery are used for the development of Micro-grid. A small hybrid grid has been modeled and simulated using the Simulink in the MATLAB. The simulation results show that the system can maintain stable operation under the proposed coordination control schemes.

Index Terms: Hybrid ac/dc micro-grid, RES, Distributed generators (DGs), Photovoltaic system, Wind turbine generator and Battery.

I. INTRODUCTION

As electric distribution technology steps into the next century, many trends are becoming noticeable that will change the requirements of energy delivery. These modifications are being driven from both the demand side where higher energy availability and efficiency are desired and from the supply side where the integration[2] of distributed generation and peak shaving technologies must be accommodated. Power systems currently undergo considerable change in operating requirements mainly as a result of deregulation and due to an increasing amount of distributed energy resources.

Revised Version Manuscript Received on November 19, 2016.

Guntuku Ravikiran, Assistant Professor, Department of Electrical Engineering, Muffakham Jah College of Engineering and Technology, Hyderabad (Telangana)-500034, India.

Mohammed Jaffar, Assistant Professor, Department of Electrical Engineering, Muffakham Jah College of Engineering and Technology, Hyderabad (Telangana)-500034, India.

Kadiyam Sasidhar, Assistant Professor, Department of Electrical Engineering, Muffakham Jah College of Engineering and Technology, Hyderabad (Telangana)-500034, India.

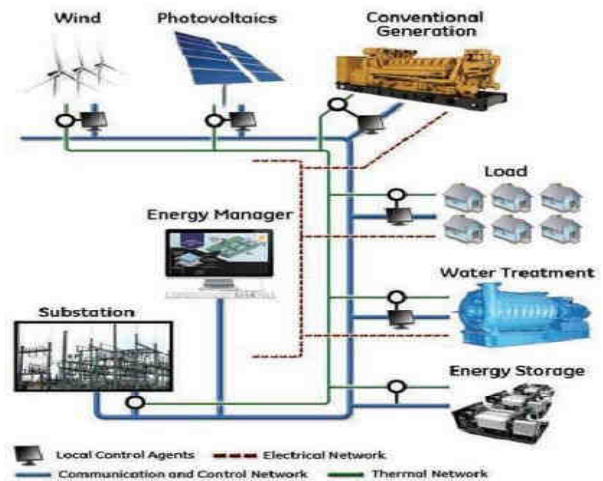

Fig.1 Micro-grid power system

The micro-grid often supplies both electricity and heat to the customers by means of combined heat and power plants (CHP), gas turbines, fuel cells, photovoltaic (PV) systems, wind turbines, etc. The energy storage systems usually include batteries and flywheels. The storing device in the micro-grid [1] is equivalent to the rotating reserve of large generators in the conventional grid which ensures the balance between energy generation and consumption especially during rapid changes in load or generation. Recently more renewable power conversion [3] systems are connected in low voltage ac distribution systems as distributed generators or ac micro grids due to environmental issues caused by conventional fossil fueled power plants [5]- [7]. On other hand, more and more dc loads such as light-emitting diode (LED) lights and electric vehicles (EVs) are connected to ac power systems to save energy and reduce CO emission. When power can be fully supplied by local renewable power sources, long distance high voltage transmission is no longer necessary. AC micro grids have been proposed to facilitate the connection of renewable power sources to conventional ac systems.

However, dc power from photovoltaic (PV) panels or fuel cells has to be converted into ac using dc/dc boosters and dc/ac inverters in order to connect to an ac grid. In an ac grid, embedded ac/dc and dc/dc converters are required for various home and office facilities to supply different dc voltages. AC/DC/AC [7-9] converters are commonly used as drives in order to control the speed of ac motors in industrial plants. Recently, dc grids are resurging due to the development and deployment of renewable dc power sources and their inherent advantage for dc loads in commercial, industrial and residential applications. The dc micro-grid has been proposed to integrate various distributed generators [11]. However, ac sources have to be converted into dc before connected to a dc grid and dc/ac inverters are required for conventional ac loads. Multiple

A Novel Multilevel Inverter based Micro Grid and its Co-Ordination Control

reverse conversions required in individual ac or dc grids may add additional loss to the system operation and will make the current home and office appliances more complicated. The smart grid concept is currently prevailing in the electric power industry.

The objective of constructing a smart grid is to provide reliable, high quality electric power to digital societies in an environmentally friendly and sustainable way. One of most important futures of a smart grid is the advanced structure which can facilitate the connections of various ac and dc generation systems, energy storage options, and various ac and dc loads with the optimal asset utilization and operation efficiency [9]. Here in Smart grid the power electronics technology plays a most important role to interface different sources and loads to a smart grid to achieve this goal.

II. MICRO-GRID STRUCTURE

Figure 2 shows a microgrid schematic diagram. The microgrid encompasses a portion of an electric power distribution system that is located downstream of the distribution substation, and it includes a variety of DER units and different types of end users of electricity and/or heat. DER units include both distributed generation (DG) and distributed storage (DS) units with different capacities and characteristics. The electrical connection point of the microgrid to the utility system, at the low-voltage bus of the substation transformer, constitutes the microgrid point of common coupling (PCC). The microgrid serves a variety of customers, e.g., residential buildings, commercial entities, and industrial parks.

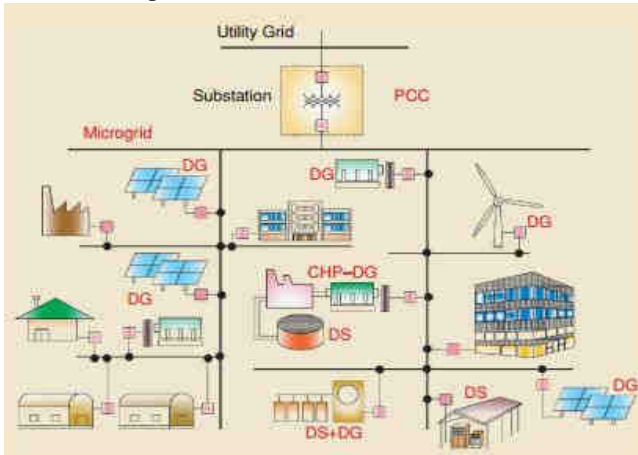

Fig.2 Microgrid structure including loads and DER units serviced by a distribution system

The microgrid of Figure 2 normally operates in a grid-connected mode through the substation transformer. However, it is also expected to provide sufficient generation capacity, controls, and operational strategies to supply at least a portion of the load after being disconnected from the distribution system at the PCC and remain operational as an autonomous (islanded) entity. The existing power utility practice often does not permit accidental islanding and automatic resynchronization of a microgrid, primarily due to the human and equipment safety concerns. However, the high amount of penetration of DER units potentially necessitates provisions for both islanded and grid-connected

modes of operations and smooth transition between the two (i.e., islanding and synchronization transients) to enable the best utilization of the microgrid resources. DER units, in terms of their interface with a microgrid, are divided into two groups. The first group includes conventional or rotary units that are interfaced to the microgrid through rotating machines. The second group consists of electronically coupled units that utilize power electronic converters to provide the coupling media with the host system. The control concepts, strategies, and characteristics of power electronic converters, as the interface media for most types of DG and DS units, are significantly different than those of the conventional rotating machines. Therefore, the control strategies and dynamic behavior of a microgrid, particularly in an autonomous mode of operation, can be noticeably different than that of a conventional power system.

A. Technical challenges in microgrid Protection system is one of the major challenges for microgrid which must react to both main grid and microgrid faults. The protection system should cut off the microgrid from the main grid as rapidly as necessary to protect the microgrid loads for the first case and for the second case the protection system should isolate the smallest part of the microgrid when clears the fault. A segmentation of microgrid, i.e. a design of multiple islands or submicrogrids must be supported by micro-source and load controllers. first is related to a number of installed DER units in the microgrid and second is related to an availability of a sufficient level of short-circuit current in the islanded operating mode of microgrid since this level may substantially drop down after a disconnection from a stiff main grid. The directions and amplitudes of short circuit currents will vary because of these conditions. In reality the operating conditions of microgrid are persistently varying because of the intermittent microsources (wind and solar) and periodic load variation. Also the network topology can be changed frequently which aims to minimize loss or to achieve other economic or operational targets. In addition controllable islands of different size and content can be formed as a result of faults in the main grid or inside microgrid.

III. SYSTEM CONFIGURATION AND MODELING

A. Grid Configuration

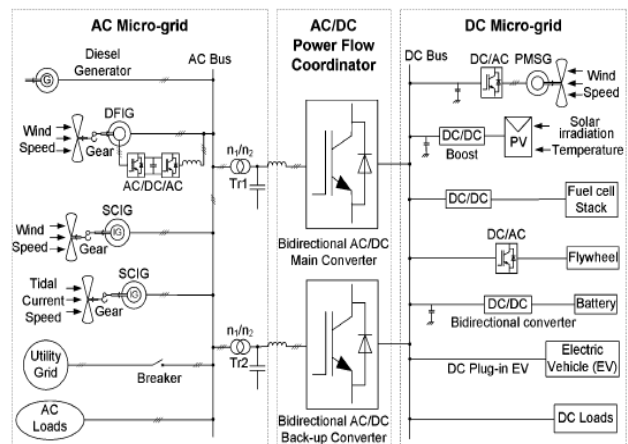

Fig.3 A hybrid ac/dc microgrid system

Fig.3 shows a conceptual hybrid system configuration where various ac and dc sources and loads are connected to the corresponding dc and ac networks. The ac and dc links are connected together through two transformers and two four-quadrant operating three phase converters. The ac bus of the hybrid grid is tied to the utility grid.

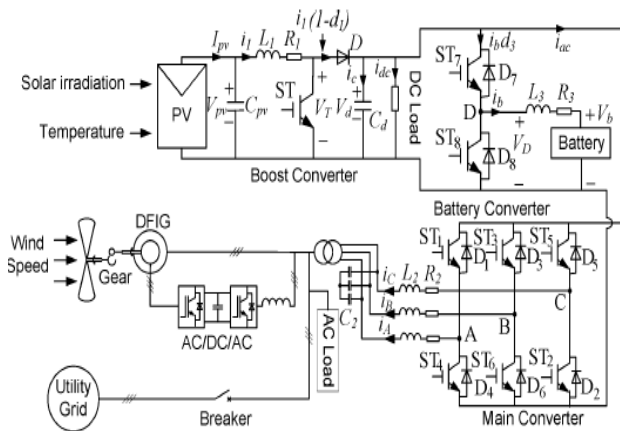

Fig.4 A compact representation of the proposed hybrid grid

A compact hybrid grid as shown in Fig.4 is modeled using the Simulink in the MATLAB to simulate system operations and controls. Forty kW PV arrays are connected to dc bus through a dc/dc boost converter to simulate dc sources. A capacitor C_{pv} is to suppress high frequency ripples of the PV output voltage.

B. Grid Operation

The hybrid grid can operate in two modes. In grid-tied mode, the main converter is to provide stable dc bus voltage and required reactive power and to exchange power between the ac and dc buses. The boost converter and WTG are controlled to provide the maximum power. When the output power of the dc sources is greater than the dc loads, the converter acts as an inverter and injects power from dc to ac side. When the total power generation is less than the total load at the dc side, the converter injects power from the ac to dc side. When the total power generation is greater than the total load in the hybrid grid, it will inject power to the utility grid. Otherwise, the hybrid grid will receive power from the utility grid. In the grid tied mode, the battery converter is not very important in system operation because power is balanced by the utility grid. In autonomous mode, the battery plays a very important role for both power balance and voltage stability. Control objectives for various converters are dispatched by energy management system. DC bus voltage is maintained stable by a battery converter or boost converter according to different operating conditions. The main converter is controlled to provide a stable and high quality ac bus voltage. Both PV and WTG can operate on maximum power point tracking (MPPT) or off-MPPT mode based on system operating requirements. Variable wind speed and solar irradiation are applied to the WTG and PV arrays respectively to simulate variation of power of ac and dc sources and test the MPPT control algorithm.

IV. PVMODELING

PV arrays are built up with combined series/parallel combinations of PV solar cells, which are usually represented by a simplified equivalent circuit model such as the one given in Fig.5

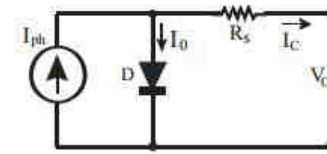

Fig.5 Simplified-equivalent circuit of photovoltaic cell

The PV cell output voltage is a function of the photocurrent that mainly determined by load current depending on the solar irradiation level during the operation.

$$V_c = \frac{AkT_c}{e} \ln \left(\frac{I_{ph} + I_0 - I_c}{I_0} \right) - R_s I_c \quad (1)$$

Both k and T_c should have the same temperature unit, either Kelvin or Celsius. The curve fitting factor A is used to adjust the I-V characteristics of the cell obtained from (1) to the actual characteristics obtained by testing. Eq. (1) gives the voltage of a single solar cell which is then multiplied by the number of the cells connected in series to calculate the full array voltage. If the temperature and solar irradiation levels change, the voltage and current outputs of the PV array will follow this change. Hence, the effects of the changes in temperature and solar irradiation levels should also be included in the final PV array model. may cause the overall system to be more expensive and complex. Plentiful multilevel converter topologies have been proposed during the last two decades. Contemporary research has engaged novel converter topologies and unique modulation schemes. Moreover, three different major multilevel converter structures have been reported in the literature: cascaded H-bridges converter with separate dc sources, diode clamped (neutral-clamped), and flying capacitors (capacitor clamped). Moreover, abundant modulation techniques and control paradigms have been developed for multilevel converters such as sinusoidal pulse width modulation (SPWM), selective harmonic elimination (SHE-PWM), space vector modulation (SVM), and others. In addition, many multilevel converter applications focus on industrial medium- voltage motor drives, utility interface for renewable energy systems, flexible AC transmission system (FACTS) , and traction drive systems.

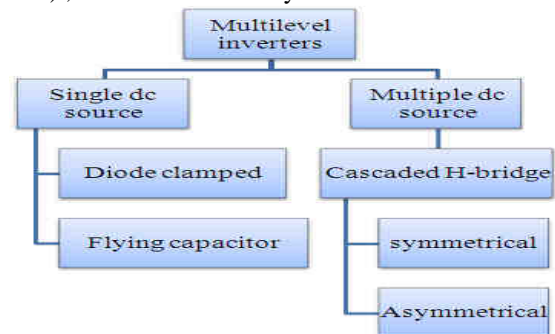

Fig.6 Classification of multilevel Inverters

A. Diode-Clamped Multilevel Inverter (DCMI)

The diode-clamped inverter was also called the neutral-point

clamped (NPC) inverter when it was first used in a three-level inverter in which the mid-voltage level was defined as the neutral point. The diode-clamped multilevel inverter uses capacitors in series to divide up the dc bus voltage into a set of voltage levels. To produce m levels of the phase voltage, an m level diode-clamp inverter needs $m-1$ capacitors on the dc bus. A single-phase five-level diode-clamped inverter is shown in Fig.7.

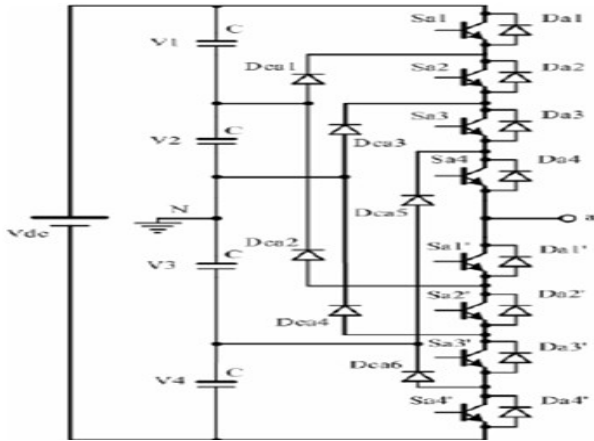

Fig.7 Five level diode clamped MLI

The dc bus consists of four capacitors, i.e., C1, C2, C3, and C4. For a dc bus voltage V_{dc} , the voltage across each capacitor is $V_{dc}/4$, and each device voltage stress will be limited to one capacitor voltage level, $V_{dc}/4$, through clamping diodes. DCMI output voltage synthesis is relatively straightforward.

V. SIMULATION RESULTS

Fig.6.1 Matlab/simulink model of conventional method

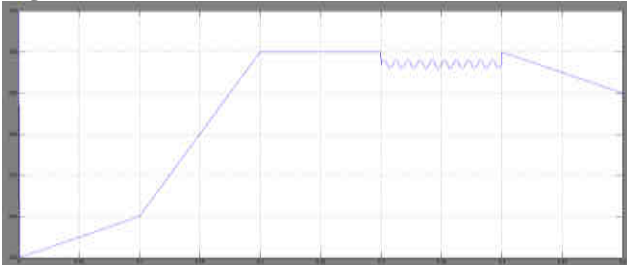

Fig.6.2 The terminal voltage of the solar panel

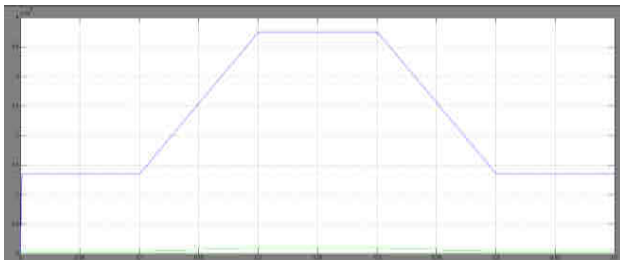

Fig.6.3 PV output power versus solar irradiation

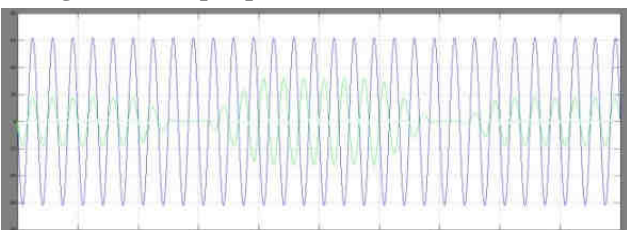

Fig.6.4 AC side voltage and current of the main converter with variable solar irradiation level and constant dc load.

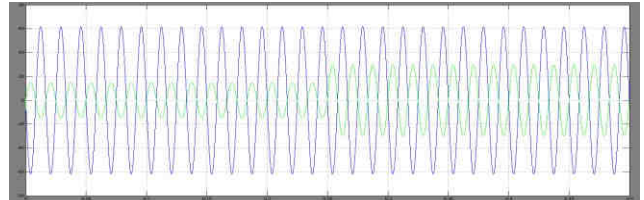

Fig.6.5 AC side voltage and current of the main converter with constant solar irradiation level and variable dc load.

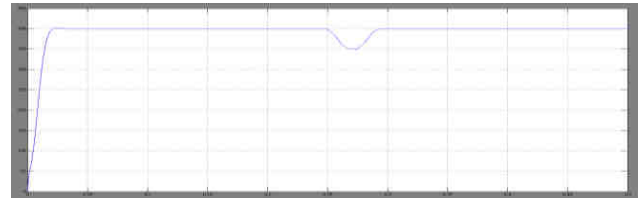

Fig.6.6 DC bus voltage transient response.

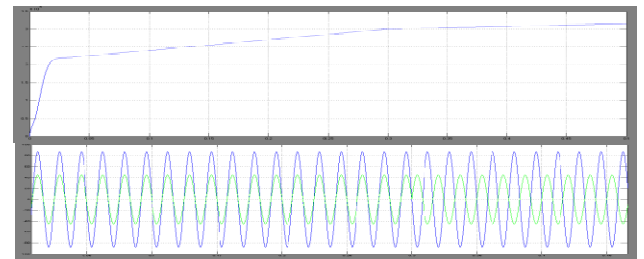

Fig.6.7 Upper: output power of the DFIG; Lower: AC side voltage versus current (Voltage times 1/3 for comparison).

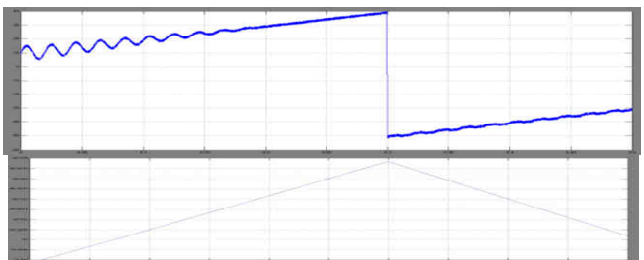

Fig.6.8 Battery charging current (upper) and SOC (lower) for the normal case.

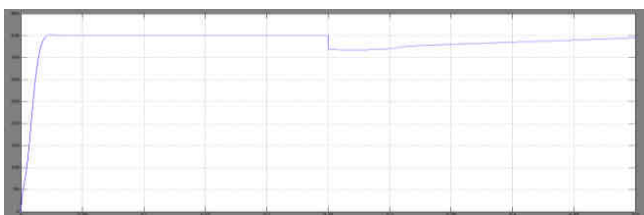

Fig.6.9 DC bus voltage transient response in isolated mode.

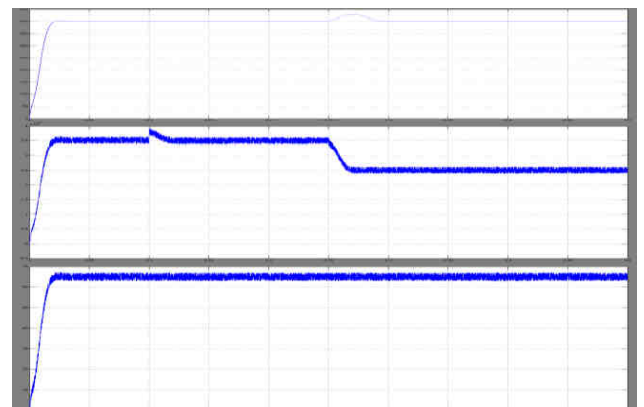

Fig.6.10 DC bus voltage, PV output power, and battery current

Fig.6.11 1Matlab/simulink model of proposed method

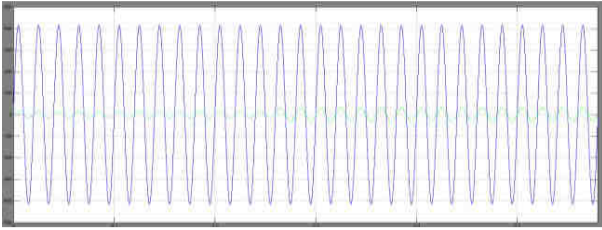

Fig.6.12 voltage and power from grid

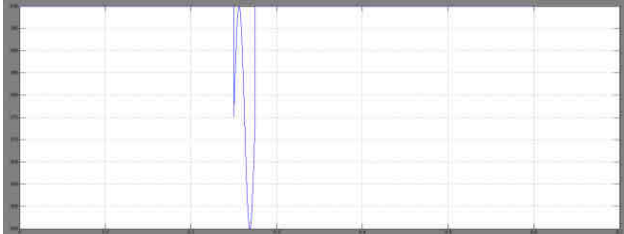

Fig.6.13DC bus voltage from grid

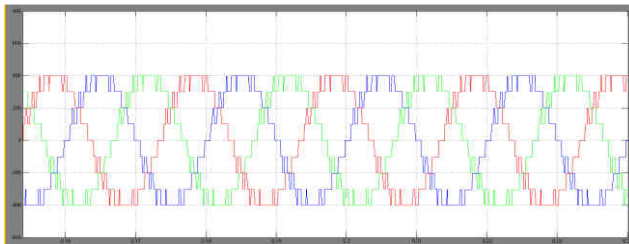

Fig.6.14 Inverter voltage

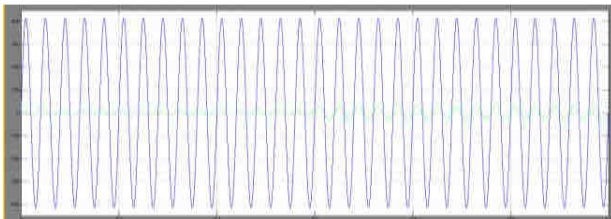

Fig.6.15 Grid voltage and current



Fig.6.16 Power at the grid



Fig.6.17 Current at battery

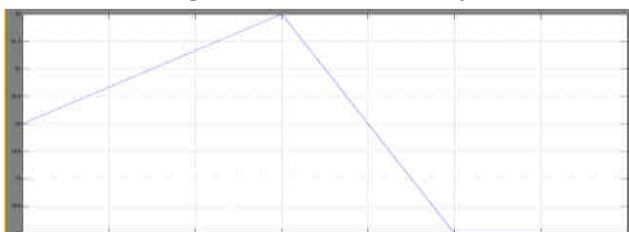

Fig.6.18 Voltage at battery

VI. CONCLUSION

A hybrid ac/dc microgrid is proposed and comprehensively studied in this paper. The models and coordination control schemes are proposed for the all the converters to maintain stable system operation under various load and resource conditions. The coordinated control strategies are verified by Matlab/Simulink. Various control methods have been incorporated to harness the maximum power from dc and ac sources and to coordinate the power exchange between dc and ac grid. Different resource conditions and load capacities are tested to validate the control methods. The simulation results show that the hybrid grid can operate stably in the grid-tied or isolated mode. Stable ac and dc bus voltage can be guaranteed when the operating conditions or load capacities change in the two modes. The power is smoothly transferred when load condition changes. Although the hybrid grid can reduce the processes of dc/ac and ac/dc conversions in an individual ac or dc grid, there are many practical problems for implementing the hybrid grid based on the current ac dominated infrastructure. The total system efficiency depends on the reduction of conversion losses and the increase for an extra dc link. It is also difficult for companies to redesign their home and office products without the embedded ac/dc rectifiers although it is theoretically possible. Therefore, the hybrid grids may be implemented when some small customers want to install their own PV systems on the roofs and are willing to use LED lighting systems and EV charging systems. The hybrid grid may also be feasible for some small isolated industrial plants with both PV system and wind turbine generator as the major power supply. The proposed system is verified at different loading conditions and performance of the system is presented in this paper.

REFERENCES

1. M. E. Ropp and S. Gonzalez, "Development of a MATLAB/simulink model of a single-phase grid- connected photovoltaic system," IEEE Trans. Energy Conv., vol. 24, no. 1, pp. 195–202, Mar. 2009.
2. Sera, R. Teodorescu, J. Hantschel, and M. Knoll, "Optimized maximum power point tracker for fast-changing environmental conditions," IEEE Trans. Ind. Electron., vol. 55, no. 7, pp. 2629–2637, Jul. 2008.
3. Bryant and M. K. Kazimierczuk, "Voltage loop of boost PWM DC-DC converters with peak current-mode control," IEEE Trans. Circuits Syst. I, Reg. Papers, vol. 53, no. 1, pp. 99–105, Jan. 2006.
4. S. Arnalte, J. C. Burgos, and J. L. Rodriguez- amenodo, "Direct torque control of a doubly-fed induction generator for variable speed wind turbines," Elect. Power Compon. Syst., vol. 30, no. 2, pp. 199–216, Feb. 2002.
5. W. S. Kim, S. T. Jou, K. B. Lee, and S. Watkins, "Direct power control of a doubly fed induction generator with a fixed switching frequency," in Proc. IEEE Ind. Appl. Soc. Annu. Meet., Oct. 2008, pp. 1–9.

Authors Profile



Mr. Guntuku Ravikiran was born in Nizamabad Dist, Telangana, India, in 1984. He received bachelor's degree in Electrical & Electronics Engineering from Padmasri B.V. Raju Institute of Technology, JNTU Hyderabad and Master degree in Embedded Systems from JNTU, Hyderabad, in 2005 and 2010 respectively. His research interest in Power Electronics, Embedded Systems and Machines.

Presently he is working as Assistant Professor in Electrical Engineering department, Muffakham Jah College of Engineering and Technology, Banjara Hills, Hyderabad, Telangana, India.

A Novel Multilevel Inverter based Micro Grid and its Co-Ordination Control



Mr. Mohammed Jaffar was born in Hyderabad, Ranga Reddy, Dist, Telangana, India, in 1986. He received bachelor's degree in Electrical & Electronics Engineering from JNTU, Hyderabad and Master degree in Power Electronics from JNTU, Hyderabad, in 2008 and 2012 respectively. His research interest in Multilevel Inverter, Power system protection and control. Presently he is working as Assistant Professor in

Electrical Engineering department, Muffakham Jah College of Engineering and Technology, Banjara Hills, Hyderabad, Telangana, India.



Mr. Kadiyam Sasidhar was born in Nellore Dist, AndhraPradesh, India, in 1981. He received bachelor's degree in Electronics & Instrumentation Engineering from JNTU and Master degree in Instrumentation & Control Systems from JNTU, Kakinada in 2004 and 2007 respectively. His research area is Control systems. Presently he is working as Assistant Professor in

Electrical Engineering department, Muffakham Jah College of Engineering and Technology, Banjara Hills, Hyderabad, Telangana, India.